



LiftWEC

DEVELOPMENT OF A NEW CLASS OF WAVE ENERGY CONVERTER
BASED ON HYDRODYNAMIC LIFT FORCES

Deliverable D4.5

3D scale model of the final LiftWEC concept selected

Deliverable Lead	Ecole Centrale Nantes
Delivery Date	20th June 2022
Dissemination Level	Public
Status	Final
Version	2.0



This project has received funding from the European Union's Horizon 2020 research and innovation programme under grant agreement No 851885. This output reflects the views only of the author(s), and the European Union cannot be held responsible for any use which may be made of the information contained therein.

Document Information

Project Acronym	LiftWEC
Project Title	Development of a novel wave energy converter based on hydrodynamic lift forces
Grant Agreement Number	851885
Work Package	WP04
Related Task(s)	T4.3
Deliverable Number	D4.5
Deliverable Name	3D scale model of the final LiftWEC concept selected
Due Date	31 st August 2021
Date Delivered	20 th June 2022
Primary Author(s)	Florent Thiebaut (ECN)
Co-Author(s)	Sylvain Haquin (ECN), Matthieu Weber (ECN)
Document Number	LW-D04-05

Version Control

Revision	Date	Description	Prepared By	Checked By
1.0	31/01/2022	Draft for internal review, missing drawings and information in red	FT	GO
1.1	07/02/2022	Second draft with modified section 6	FT	MF
1.3	10/06/2022	Final version for review	FT	MF
2.0	17/06/2022	Release to EU	MF	



EXECUTIVE SUMMARY

Following the experimental testing of a two-dimensional LiftWEC concept and analysis of the results, the final concept is due to be tested in the Hydraulic and Offshore Engineering wave tank (HOET) in Ecole Centrale de Nantes (ECN). This document provides specifications of the physical model, that were derived through discussions with the partners involved in the numerical modelling work package, through considerations of the prototype characteristics, testing facilities and ECN physical model design and testing know how. The model allows testing of configurations with one or two foils and with adjustments of the foil angle of attack, between tests. The model is to be tested in the HOET under a hexapod capable of six degree actuation. The idea behind this approach is to use the hexapod to test a fixed model with variable depth and orientation and to test a model moving in a controlled motion cycle to simulate a floating model. The motion of the rotor is controlled using a power take-off (PTO) system consisting of an electrical machine which can be operated in position, speed and torque control. The quantities measured are: the PTO torque, radial and tangential loads on the axis of each foil, absolute angular position of the rotor and wave elevation upstream and downstream of the model. From those measured quantities, rotor velocity and acceleration as well as captured power can be inferred. The details of the various components as well as technical drawings of the parts of the model are provided herein.



TABLE OF CONTENTS

EXECUTIVE SUMMARY	3
TABLE OF CONTENTS	4
1 INTRODUCTION	5
2 MODEL PURPOSE	5
3 DESIGN CRITERIA	5
3.1 Realistic deployment site	5
3.2 Testing facility	6
3.3 Scaling considerations.....	7
4 DESIGN CONSIDERATIONS AND DETAILS	7
4.1 Overall model design and assembly	7
4.2 Hydrofoils	11
4.3 Power take-off and control system.....	11
4.4 Hexapod	13
4.5 Qualisys motion camera system	14
4.6 Instrumentation	14
4.6.1 General considerations	14
4.6.2 Detailed instrumentation specifications.....	15
4.6.3 Instrumentation signal wiring	16
4.7 Data acquisition system	16
5 MANUFACTURING	17
6 MODEL SETUP AND ASSEMBLY	17
6.1 Model assembly and setup outside the basin	17
6.2 Model setup in the basin	17
6.2.1 Tripod	17
6.2.2 Hexapod	17
6.2.3 Model assembly under the hexapod	18
6.3 Foil pitch modification	18
6.4 Model setup above the basin	18
7 REFERENCES	18
APPENDICES	19
A. TECHNICAL DRAWINGS	19



1 INTRODUCTION

This document describes the design process and the detailed design of the 3D wave tank model of the LiftWEC concept, including one or two foils, which will be tested at Ecole Centrale Nantes.

The document starts by detailing the purpose of the model and is then followed by the description of the design criteria. Finally, the detailed design is provided and includes technical drawings.

2 MODEL PURPOSE

The 3D model is to be tested in the Hydrodynamics and Ocean Engineering tank (HOET) in Ecole Centrale Nantes (ECN) as part of Task 4.4. It is designed based on outputs from WP2 and WP3 in order to represent as closely as possible the final LiftWEC concept.

The model is designed to allow some degree(s) of power take off control as specified by the development of the control strategies (WP5). It integrates instrumentation in order to measure the wave field, the foil loads and power take off behaviour.

The main purpose of this experimental model is to represent the behaviour of the final LiftWEC concept. It is designed at 1:20 scale, which is the largest scale that can be tested in the tank, based on tank dimensions and wave capabilities. Due to scaling issues, the model with all its control and instrumentation cannot be built as a floating structure; however it is placed under a hexapod that can simulate a static model at various depths and orientations or a moving model with actively controlled motions.

3 DESIGN CRITERIA

The design criteria described in this section is the outcome of discussions with all project partners , with consideration of the full-scale wave climate at a realistic site, the constrains associated with the ECN testing facilities and the experience of the ECN team in model design and testing.

3.1 REALISTIC DEPLOYMENT SITE

In order to quantify realistic wave conditions that a LiftWEC device would experience when deployed at full-scale, we have been using the open access hindcast wave climate database HOMERE developed by the French research institution IFREMER to define the incident wave climate. More details on the database can be found in [1]. The site considered is south-west of Brittany (47.84° N, 4.83° W) as shown Figure 3-1. From the HOMERE database, it was possible to quantify the wave climate for the 2001-2010 period in terms of a scatter diagram, which is presented in Figure 3-2.



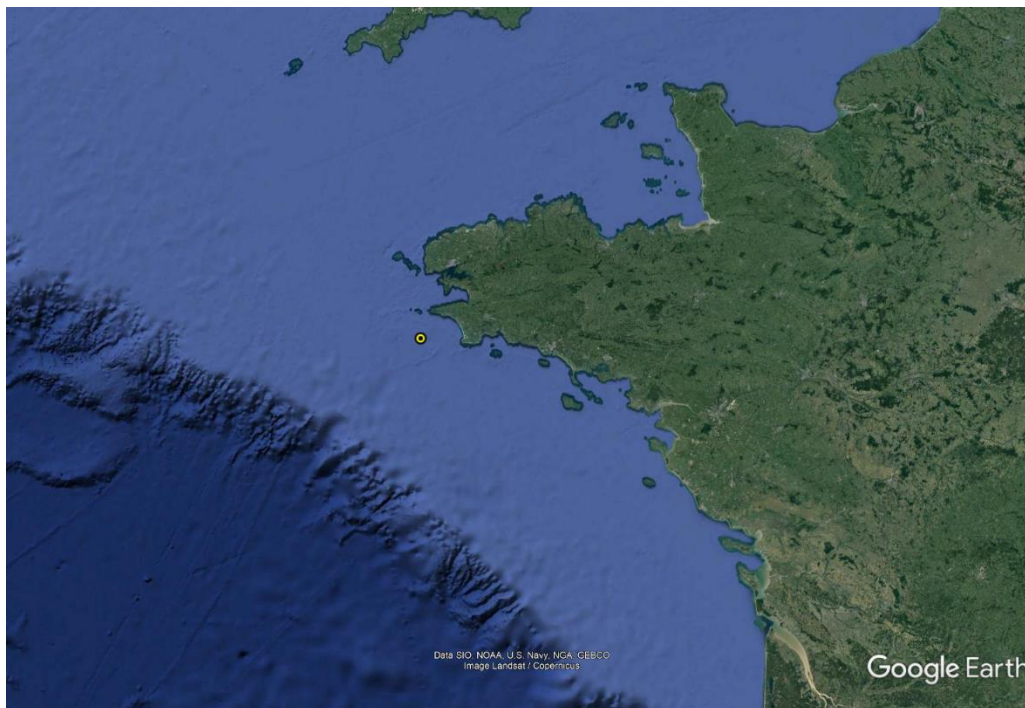

Figure 3-1: Location of the deployment site (yellow dot)

Total	0.00	0.02	1.23	7.12	16.12	20.17	18.91	14.60	10.58	6.30	2.98	1.32	0.49	0.11	0.05	100.00
8.00								0.00	0.01	0.11	0.11	0.08	0.05	0.01		0.37
7.50								0.00	0.04	0.09	0.09	0.03	0.03	0.00		0.30
7.00								0.04	0.10	0.13	0.07	0.05	0.02	0.00	0.01	0.43
6.50							0.00	0.08	0.18	0.21	0.11	0.05	0.02	0.00	0.00	0.66
6.00							0.03	0.27	0.40	0.34	0.16	0.08	0.02	0.00		1.31
5.50							0.14	0.49	0.48	0.38	0.12	0.07	0.02	0.01		1.72
5.00						0.02	0.46	0.75	0.69	0.55	0.19	0.08	0.06	0.01		2.80
4.50						0.15	0.85	0.97	0.87	0.39	0.24	0.10	0.02	0.01	0.01	3.61
4.00				0.03	0.53	1.16	1.14	0.94	0.58	0.33	0.11	0.03	0.01	0.00		4.86
3.50				0.26	1.07	1.44	1.19	1.01	0.58	0.27	0.14	0.05	0.00	0.00		6.02
3.00			0.04	0.94	2.07	1.81	1.75	1.29	0.77	0.36	0.14	0.04	0.01	0.00		9.22
2.50		0.00	0.37	2.61	3.27	2.90	2.18	1.52	0.84	0.47	0.18	0.08	0.01	0.00		14.42
2.00		0.06	1.36	3.90	4.28	4.39	2.92	1.85	0.93	0.33	0.14	0.03	0.01			20.19
1.50		0.56	3.22	4.93	5.87	4.30	2.28	0.95	0.30	0.11	0.07	0.01	0.01	0.02		22.63
1.00	0.02	0.60	2.08	3.38	2.85	1.39	0.53	0.23	0.08	0.02	0.01	0.00	0.00	0.00		11.19
0.50		0.00	0.06	0.08	0.07	0.04	0.01									0.26
	3.0	4.0	5.0	6.0	7.0	8.0	9.0	10.0	11.0	12.0	13.0	14.0	15.0	16.0	17.0	Total

Figure 3-2: Scatter diagram for the deployment site for the period 2001 – 2010

3.2 TESTING FACILITY

Given that the LiftWEC concept relies on lifting surfaces, and that these are affected by Reynolds numbers, it is desirable to have water particle wave induced velocities as high as possible and therefore to carry out the experiments in as large waves as possible (to minimise Reynolds Number effects when using Froude Scaling to define the key device dimension), implying a large wave tank facility. The 3D nature of the tests implies that the most appropriate testing facility is a wide tank. The

ECN Hydrodynamics and Ocean Engineering tank (HOET) was selected for this testing. It is 50 m long, 30 m wide and has a depth of 5 m (Figure 3-3).

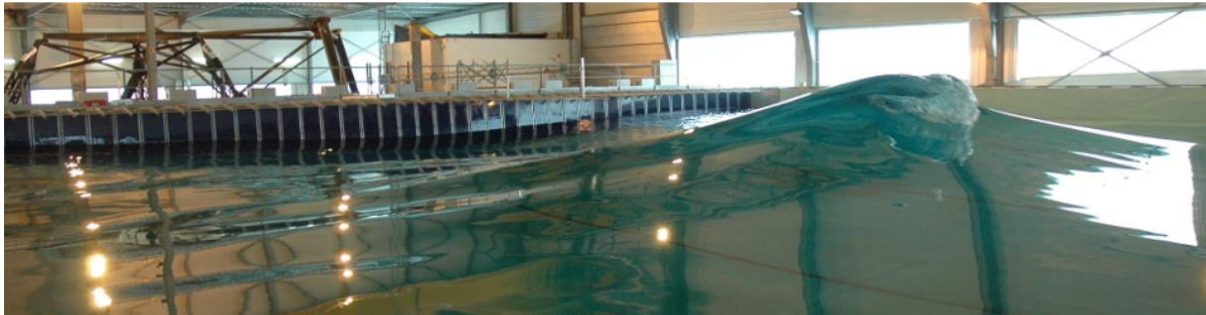

Figure 3-3: ECN Hydrodynamics and Ocean Engineering tank (HOET)

The tank is equipped with a segmented wave maker composed of 48 hinged flaps distributed over the width of the basin. The wave maker control software, used together with enhanced control laws from the literature and implemented at LHEEA (Dalrymple method, Molin method (disc or rectangle)), can generate either idealised theoretical waves (e.g. monochromatic waves, wave packets) or complex representative sea states. This powerful wave maker can generate waves up to 1.1m high. At the other end of the basin, a seven meters long passive stainless steel beach with quadratic profile dissipates most of the wave energy through breaking processes.

The tank is also equipped with several gantries, to allow staff access to models and support instrumentation, signal conditioning and acquisition materials.

3.3 SCALING CONSIDERATIONS

The scatter diagram in Figure 3-2 shows that sea states with $H_{m0} \leq 4\text{m}$ and $T_E \leq 11\text{s}$ cover just under 90% of the sea states encountered at the site. (i.e. 88.8% in terms of H_{m0} and 88.75% in terms of T_E). $T_E = 11\text{s}$ corresponds to $T_p = 12.83\text{s}$ for a JONSWAP spectrum with $\gamma = 1$.

In term of wave height, the minimum scaling factor is about 1:10 but this means testing sea states with peak periods of up to 4s. This can be generated in the wave tank but the quality of the waves is typically lower and there are larger wave reflections at the absorbing beach. It was therefore decided to build the model at 1:20 scale, limiting the peak period to 2.9s for irregular sea states and a significant wave height of 0.2m. In regular waves, the larger wave will be with $H=0.4\text{m}$ and $T=2.9\text{s}$.

4 DESIGN CONSIDERATIONS AND DETAILS

4.1 OVERALL MODEL DESIGN AND ASSEMBLY

The overall model assembly, illustrated in Figure 4-1, includes:

- A support structure composed of a tripod fixed on the tank floor and supporting a six degree of motion hexapod.
- A support structure connecting the hexapod to the model rotor.

- The model rotor fitted with a central shaft for rigidity and connection to the power take-off, one or two hydrofoils and an arm on either side connecting the central shaft with the hydrofoils. The rotor arms are designed to reduce its drag coefficient with a hydrodynamic shape around the arms and load cells.
- An electrical power take off located in a waterproofing sleeve 0.5m from the rotor arm, so that it has a minimal and insignificant interaction with the model hydrodynamics. Its shaft is directly coupled to the model rotor and is aligned with its horizontal axis of rotation, which is perpendicular to the wave propagation direction and located at adjustable depth between 0.5 and 0.8m below the still water level.
- A second waterproofing sleeve on the other side of the rotor with other instrumentation and a slip ring connecting cables from load cells measuring hydrofoil forces.
- Winglets that can be placed at both ends of each foil. They are cut so that the edges are 30mm from the closest point on the foil surface.

The model design allows the following variations:

- Number of hydrofoils used: zero, one or two hydrofoil configurations are considered
- Pitch of the hydrofoil fixed during a test but can be changed manually between tests.
- Model position in the water can be changed with the actuation of the six degree hexapod actuator. While it can provide active real time motion during a test, it is planned to test in fixed position, with the rotating shaft always horizontal, use the vertical motion to set the depth of the axis of rotation and the rotation around the Z axis to set the incident wave direction. In addition, several tests with active motion to estimate the influence of floating model motions.
- Rotor position, speed or torque with real time control on the electrical power take off.

The main dimensions of the experimental setup are summarised in Table 4-1.

Table 4-1: ECN 2D experimental setup main geometry

Description	Unit	Dimension
Tank length	m	50
Tank width	m	30
Tank depth	m	5
Hydrofoil length	m	1.49
Hydrofoil profile		NACA0015, curved with 0.3m radii
Hydrofoil chord length	m	0.3
Hydrofoil chord curve radius	m	0.3
Hydrofoil truncated trailing edge thickness	Mm	2
Rotor diameter	m	0.6
Pitch angles	degrees	[-12, -8, -4, 0, 4, 8, 12]
Depth of rotor axis	m	Adjustable between 0.5 and 0.8
Number of hydrofoils		1 or 2
Winglets dimensions	mm	30mm outside foil section



Figure 4-1 provides an overview of the testing setup installed in the HOET. It includes the tripod structure, six degree motion hexapod and the LiftWEC 3D model assembly. The tripod is installed in the basin for the whole duration of the project while the hexapod and LiftWEC 3D model. Figure 4-2 shows a close-up view of the LiftWEC 3D model. Figure 4-3 focuses one of the four arms, from two perspectives, and showing the rigid central structure, load cells with cables and the external hydrodynamic shape (semi-transparent). Figure 4-4 shows the PTO assembly and the torque meter protected by a waterproofing sleeve. Finally, Figure 4-5 shows the details of the rotary encoder and slip-ring arrangement protected by a second waterproofing sleeve.

Detailed technical drawings are provided in appendix A

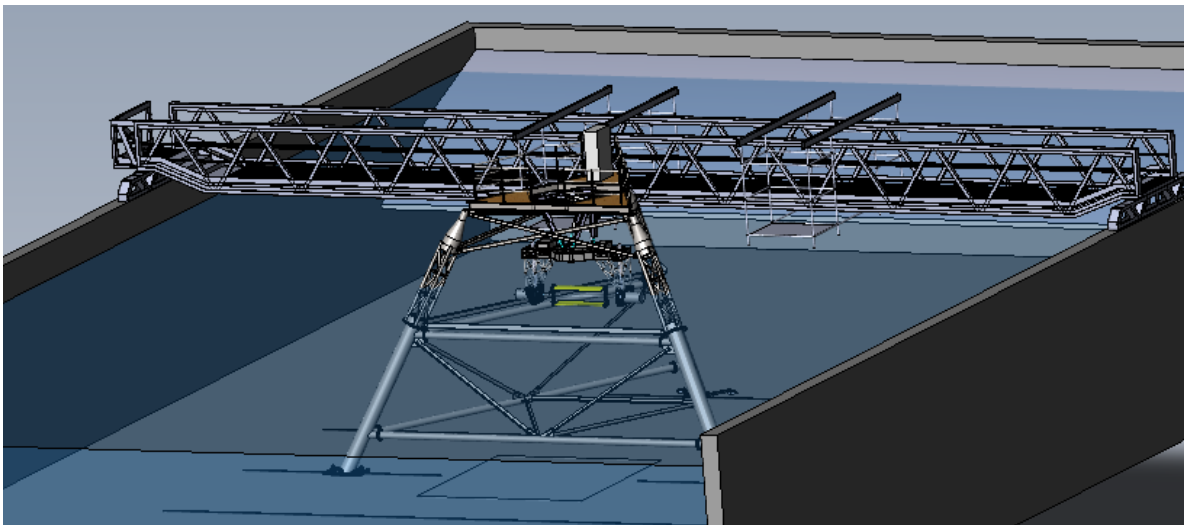

Figure 4-1: Overall CAD view of the experimental set-up in the wave basin

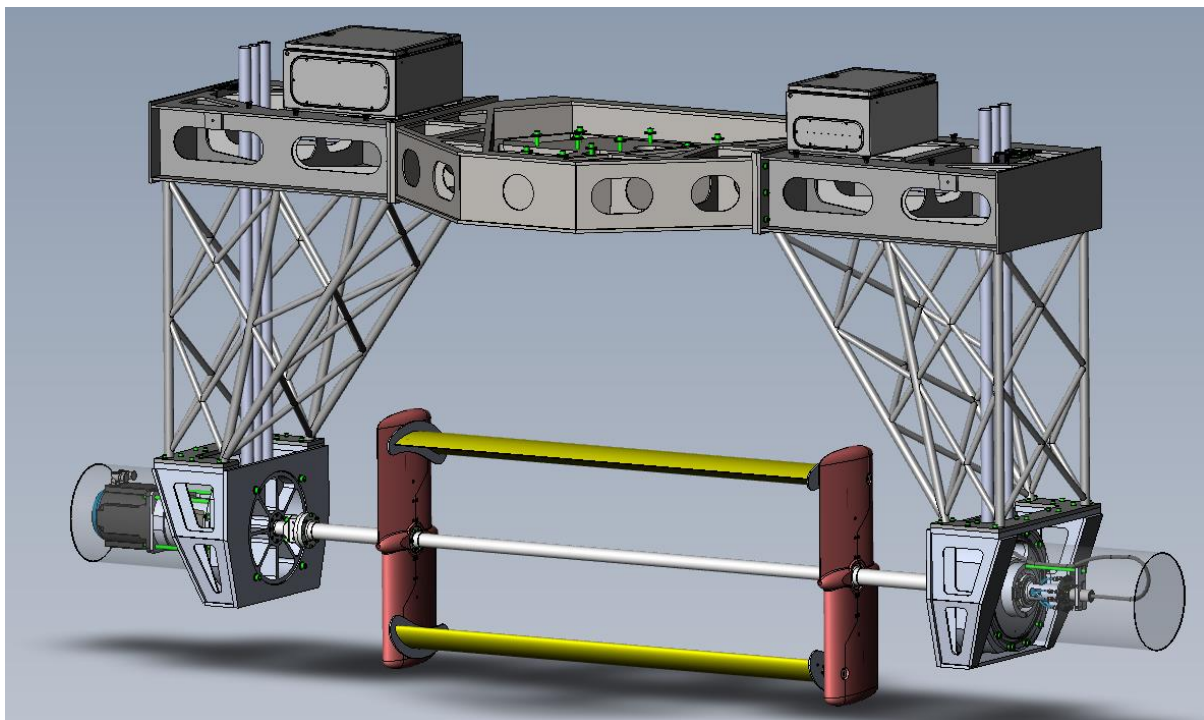

Figure 4-2: Overall CAD view of the model built for LiftWEC 3D experiments

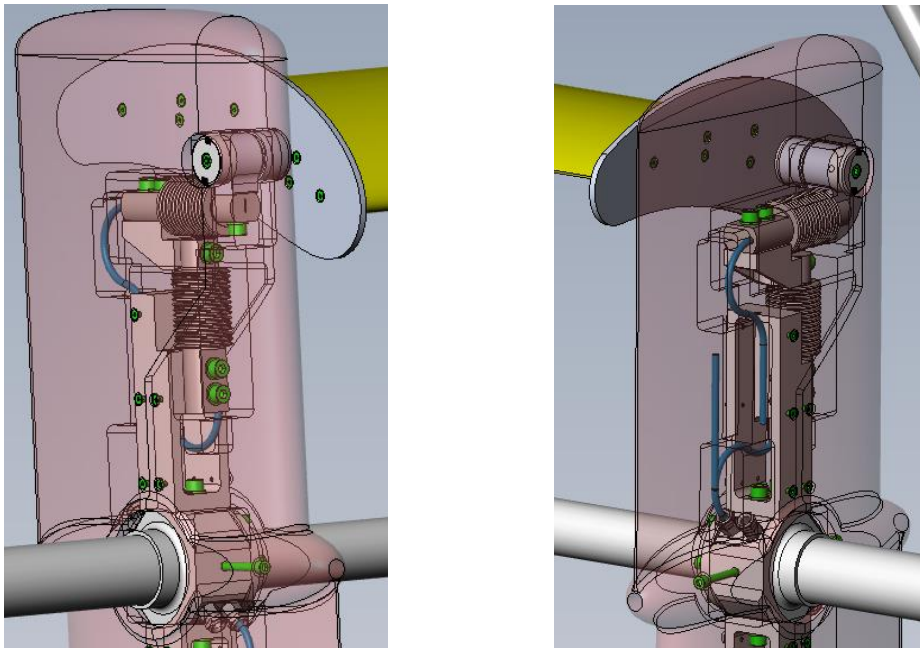

Figure 4-3: Detail CAD view of one of the four arms and load cells supporting the foils.

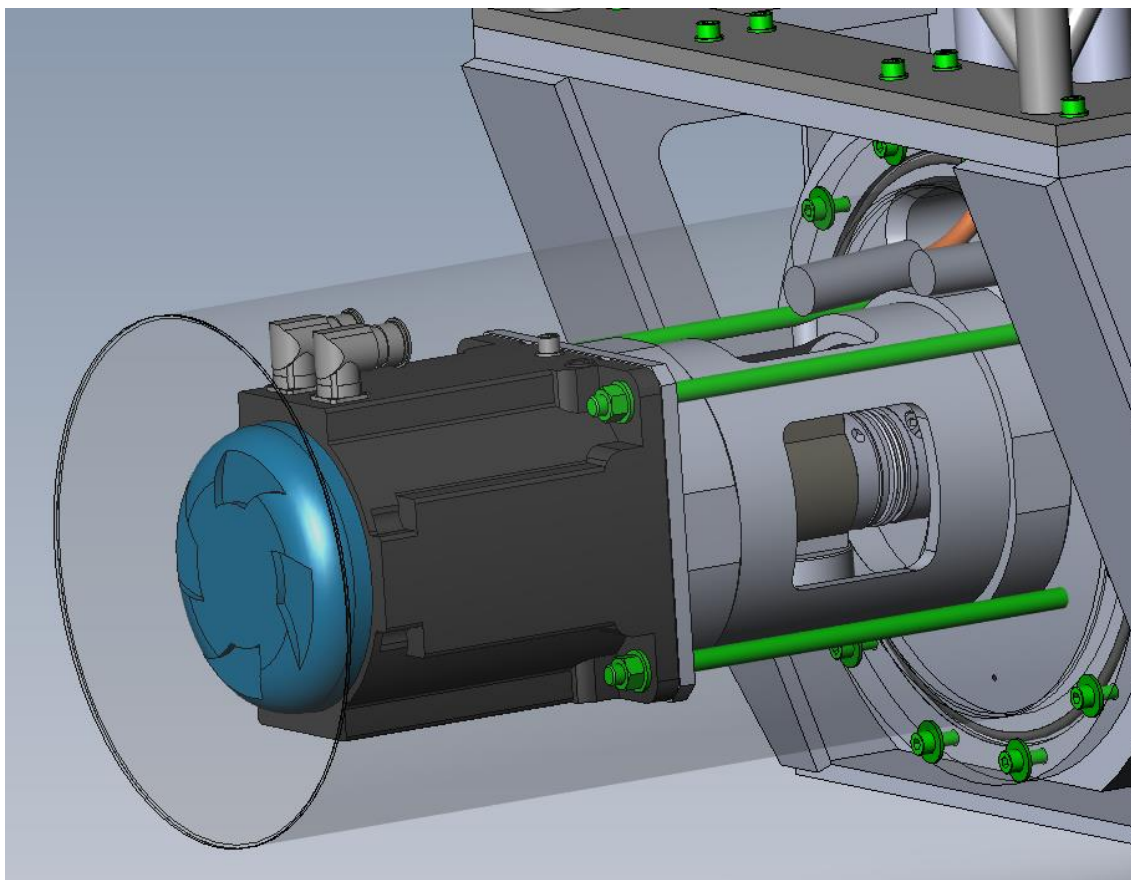

Figure 4-4: Detail CAD view of the PTO and torque transducer inside a dry sleeve

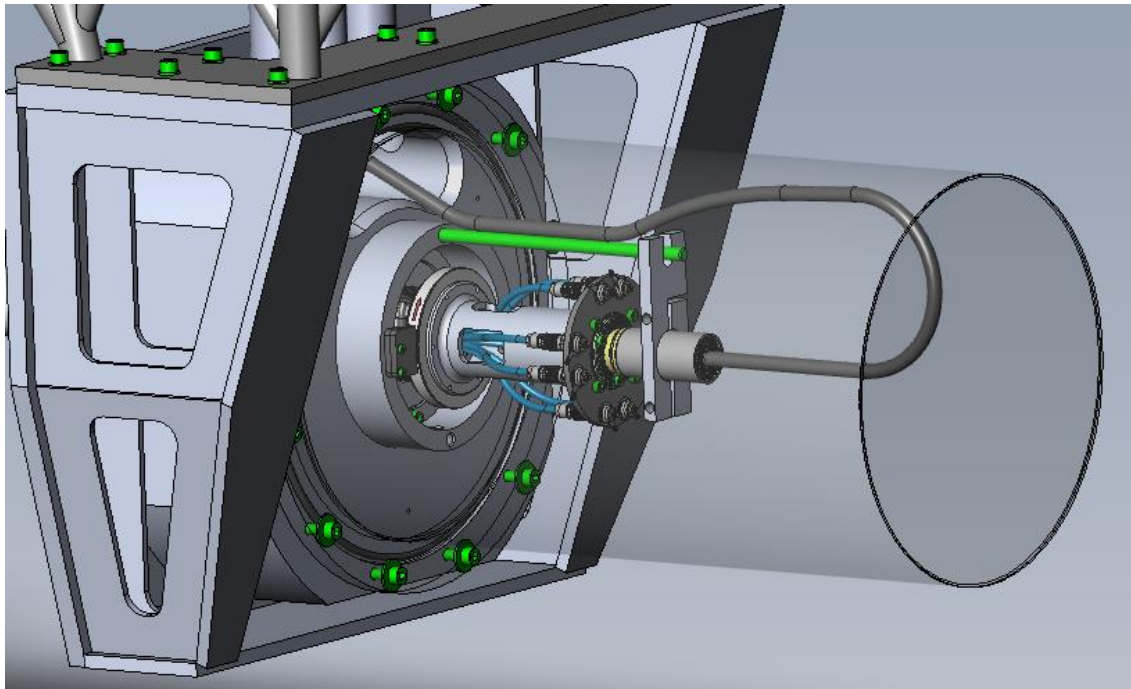

Figure 4-5: Detail CAD view of the slip ring and encoder inside a dry sleeve

4.2 HYDROFOILS

The nominal foil profile retained for the model is the NACA0015 with a chord length equal to the rotor radius (see Table 4-1). Compared to a standard NACA0015 profile, the chord is not straight but curved, with a radius corresponding to the rotor radius of 0.3 m.

The foils are made of a urethane machinable tooling block material, the one used here is Labelite, produced by the company Sika. Using this material the foils are structurally strong enough to minimise deformation while enabling the mass to be as close as possible to the displaced mass of water, i.e. so that it is neutrally buoyant.

Due to manufacturing considerations, the trailing edge of the foil cannot be as sharp as that of the theoretical profile and it is therefore truncated perpendicularly to the chord line at a thickness of 2mm.

4.3 POWER TAKE-OFF AND CONTROL SYSTEM

The model power take-off is a brushless permanent magnet electrical machine, connected to the rotor main shaft through a torque meter. It is composed of:

- Motor Kollmorgen Catridge C061B-13-3105 with the following specifications:
 - High Resolution Sine-Cosine-resolver, Singleturn, Heidenhain ECN, EnDat
 - Stall Torque = 32.60Nm Peak Torque = 75.6 Nm
 - Voltage Supply = 230 VAC Rated Speed = 1950 rpm

- Drive AKD-P02406-NBCC-x069
- Dump load regen external resistor BAF(U) 200-33 (200W)

The motor control system will allow the following control modes:

- “Fixed position” mode: the rotor can be placed and held in position at any angle.
- “Constant speed” mode: from its starting position, in “fixed position” mode, the motor accelerates up to the required speed. The acceleration starts at a time (delay after the wave generation starts) that must be set before the wave starts. It will be used to control the phase angle between the wave and the rotor position. Once the rotor reaches the required speed, the controller modulates the rotor torque to follow that target speed. This is illustrated in Figure 4-6 where t_0 is the time when the wavemaker starts and t_1 is the chosen delay when the rotor speed control starts. This speed control mode can also be used in the absence of incoming waves. In this configuration, the PTO drives the rotor at a constant speed. This approach can be used to investigate the wave radiation characteristics of the device.
- “torque control” mode: at negative or zero speed, the rotor torque is set to zero. For positive rotational speeds, a damping torque (proportional to the rotational speed) is applied to the rotor, resisting its motion. The value of the torque applied is capped i.e. as the rotor speed increases, there is a point where the torque applied by the PTO is no longer proportional to the rotational speed but becomes constant. If the rotational speed goes down, in such a way that the damping torque falls below the torque cap, then the torque becomes again proportional to the rotational velocity. This control strategy is illustrated in Figure 4-7. The damping coefficient and the torque limit can be set (within the limits of the motor capabilities). The system might not be self-starting with this control configuration, in which case, the torque control sequence will be preceded by a short speed control sequence to get the rotor spinning.
- “Speed time series” mode: this mode generates a controlled motion with any speed profile programmed in a text file, giving the speed at each time step of one millisecond. It is designed to follow the speed time series in the file and repeat the same cycle until the test stops, therefore the speed at the beginning and at the end of the file must be the same.
- “Position time series” mode: this mode generates a controlled motion with any position profile programmed in a text file, giving the position at each time step of one millisecond. It is designed to follow the position time series in the file and repeat the same cycle until the test stops, therefore the position and speed at the beginning and at the end of the file must be the same.



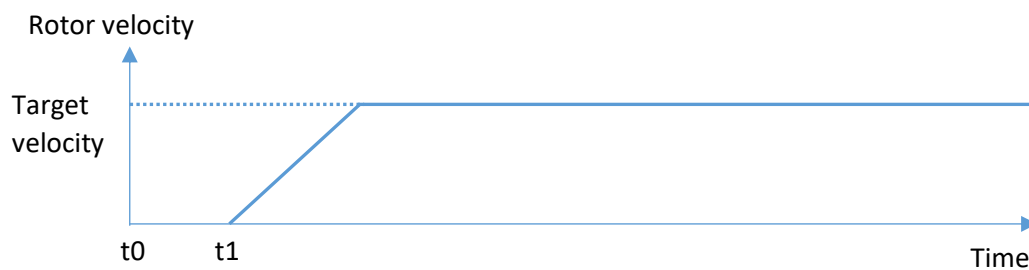

Figure 4-6: Constant speed mode

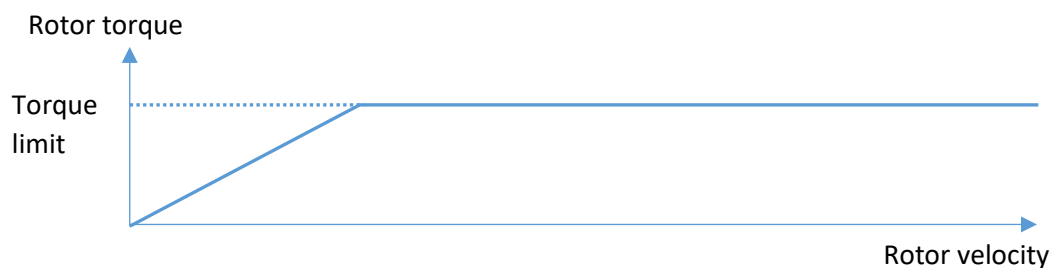

Figure 4-7: Torque mode

The control of the PTO will be implemented using a National Instruments CompactRIO connected to the motor drive. The control algorithms will be programmed in LabVIEW.

4.4 HEXAPOD

The Mistral forced motion generator, Hexapod, was supplied by the company Symétrie and is a 6 degrees of freedom platform fitted with six electric actuators controlled on a dedicated computer. Some characteristics are given in Figure 4-8.

Maximum static load	1000 kg
Maximum speeds	1 m/s in X or Y 0.6 m/s in Z
Maximum strokes	± 0.465 m in X or Y ± 0.300 m in Z
Motion frequency range	0 – 3 Hz
Attitude absolute uncertainties (factory data)	Position < 0.1 mm and Rotation < 0.05°

Figure 4-8: Hexapod main characteristics

The control software drives the platform motion according to a 6-axis (3 translational and 3 rotational motions) demanded time-series defined in an ASCII file (i.e. the motion target) and the user-defined point of rotation. The real-time motion control is carried out by comparing the actuators target positions with current positions calculated from the motor resolvers. The real-time motion is available also for data collection by a dedicated acquisition system, for example in order to get synchronised measurements of forces and pressures.

4.5 QUALISYS MOTION CAMERA SYSTEM

The Qualisys motion camera system is capable of measuring the 3D position of reflective spherical objects based on the comparison of more than two camera views. When the positions of at least four reflective objects are measured on a rigid body, the software can calculate the 6 degree position of the body. It will be used to record the hexapod motion, only in tests with dynamic motion. This will provide the model motion in a dataset that can be synchronised with the waves and other sensors.

4.6 INSTRUMENTATION

4.6.1 General considerations

The instrumentation is designed to measure the following quantities:

- Wave elevation upstream and downstream of the model, with resistive wave gauges (see picture in Figure 4-9) and ECN built signal amplifiers.
- 1 additional wave gauge at the model location during wave calibration only
- Radial and tangential forces on each foil.
- Torque on the PTO shaft
- Absolute angular position of the rotor
- Position of the hexapod
- Underwater video

Measurements from all the above instruments will be synchronised.

These sensors are the same as the sensors used in the 2D model except the load cells on the foils have a larger range of measurement due to the longer foil span and larger wave conditions. The choice was based on analysis of the load measurements in the 2D model. The minimum and maximum values are summarised in Table 4-2 for the largest of the four load cells in each direction. As a worst case scenario, these values would be multiplied by 3 due to the foil span increasing from 0.49m to 1.49m. Therefore, 294 N range was chosen in the tangential direction and 490N in the radial direction with, in each direction, one sensor on each side of the foil. About 50 percent higher range were chosen to allow for larger wave conditions.

Table 4-2: 2D model extreme values measured on a single sensor with 0.49m long hydrofoil

Parameter	Unit	Minimum value	Maximum value
Tangential force	N	-60	70
Radial force at optimal tangential force	N	-100	125



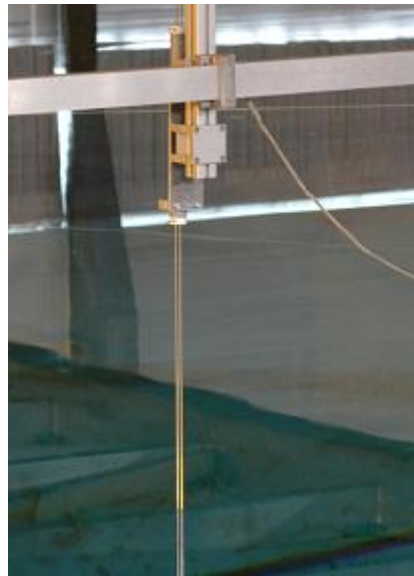

Figure 4-9: Picture of a resistive wave gauge in the ECN wave tank

4.6.2 Detailed instrumentation specifications

- PTO torque transducer
 - DRBK II 100 A produced by the German company ETH-messtechnik, with a torque rating of 100Nm
- Rotor angular position
 - The rotor angular position is measured by the motor built in resolver, coupled to the rotor in a direct drive manner. However, the resolver signal cannot be directly connected to the data acquisition system and has to be first processed by the motor drive. To avoid uncertainty and delay associated with this processing, it was decided to mount on the shaft an encoder, which is exclusively dedicated to measurements and directly connected to the data acquisition system. A contactless magnetic type encoder with a resolution of 4096 pulses per turn is used. The encoder is produced by the German company Automation Sensorik Messtechnik (ASM). The magnetic disk model is PMIR5-50-64-M-83-AB and that of the reader head is PMIS4-50-64-20KHZ-TTL-Z3-3M-S
- Foil loads are measured by two orthogonal load cells mounted between the axis of the foil and the arms of the rotor on each side of the foil. For each foil, there are four load cells, two on each side. The load cells selected are manufactured by the German company HBM. The models details are:
 - K-Z6-F-C3-0050-N-S3-N (490N capacity) for the radial direction
 - K-Z6-F-C3-0030-N-S3-N (294N capacity) for the tangential direction
- Underwater video
 - Underwater video will be captured using a bespoke camera system developed by ECN and based on an off-the-shelf PTZ CCTV camera with HD resolution and an optical zoom of x25. The camera and its waterproof housing are shown in Figure 4-10.

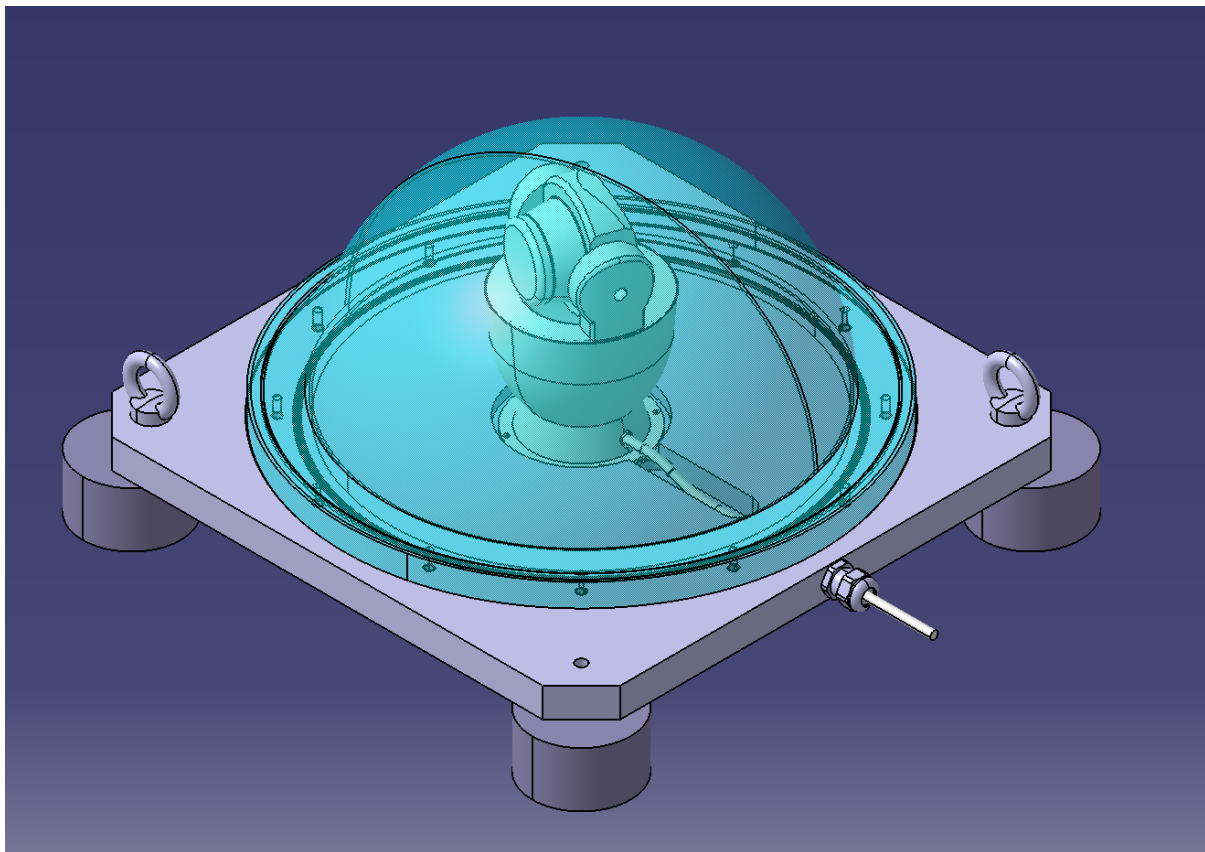

Figure 4-10: CAD view of the underwater camera system

4.6.3 Instrumentation signal wiring

All the foil load measurements are carried out within a rotating assembly and the corresponding signals need to be transferred to a fixed location. The load cells are waterproof and their cables are in the water up to the centre of the rotating shaft, entering the shaft through IP 68 cable glands and then run through the shaft up to a dry housing at the opposite side of the motor. They are then connected to the fixed section of the housing through a slip ring. The slip ring used is specially designed for weak instrumentation signals such as those from strain gauge bridges. The model used is a SR36M 36-way slip-ring made by the US company Michigan Scientific.

However, the connection of the torque transducer and magnetic encoder, is achieved using a contactless process built-in the sensors.

For all instruments, the wires are then run through dry vertical tubes and connected to the data acquisition system placed directly above the model to minimise cable length.

4.7 DATA ACQUISITION SYSTEM

All sensors measurement time series will be recorded at 128 Hz, in a synchronous manner using a combination of National Instrument (CompactRIO) and HBM (Quantum) hardware.

The motion of the hexapod is recorded on the control computer which is not electrically synchronised with other acquisition systems. When the hexapod generates an active motion of the model during a

test, the Qualisys motion camera system will record the model motion in the Qualisys Track Manager software which includes an electrical trigger that allows synchronisation with other sensors.

5 MANUFACTURING

ECN carried out all the model design but does not have capabilities in-house for the manufacturing of its large mechanical parts. All parts, not available in ECN, will be sourced from suppliers with which ECN has an established relationship.

Technical drawings of all the most relevant parts are in appendix A.

6 MODEL SETUP AND ASSEMBLY

This section describes the broad plan for model setup and assembly in all its testing location outside and in the basin. As the model is being built and commissioned, this plan is likely to be refined and/or updated.

6.1 MODEL ASSEMBLY AND SETUP OUTSIDE THE BASIN

The model will first be installed and fully assembled outside the basin on two flat supports, placed underneath the model holding structure on either side of the rotor. This allows preliminary testing in the air, to ensure all the system works properly, and carry out other testing such as static and centrifugal forces measurement.

The elements of the model assembled during this operation include all LiftWEC model parts but not the hexapod or the tripod.

6.2 MODEL SETUP IN THE BASIN

The model installation in the basin, after preliminary testing, under the hexapod is described for the tripod, hexapod and LiftWEC model individually.

6.2.1 Tripod

The tripod structure holding the hexapod will be installed at the beginning of the project for the whole duration of the test campaign. It is composed of two elements and will require divers for laying and connecting the lower element at the bottom of the tank and for connecting the two elements together.

6.2.2 Hexapod

The hexapod will be lifted and placed on the tripod with the overhead crane. It is directly screwed on the tripod, which is designed with guides so that the hexapod sits at the desired location. Cables and control system will be placed partly on the tripod and on the nearby footbridge. The control computer will be placed on the side of the tank, near the basin control and acquisition system.



6.2.3 Model assembly under the hexapod

After model assembly and after the hexapod is fixed on the tripod, the LiftWEC model assembly (PTO, rotor, foils, sensors, and control and acquisition cabinets as shown in Figure 4-2), will be lifted in one part. It will be placed on a floating barge using the overhead crane and then dragged under the hexapod to be bolted on the hexapod lower plate. The system power supply will be placed on the nearby footbridge.

6.3 FOIL PITCH MODIFICATION

The foil pitch modification can be done with the model in place for testing by lifting the hexapod to its highest position, in which the foil axis will be about 50 millimetres under the water surface. Pitch modification is estimated to take between 0.5 and 1 hour.

6.4 MODEL SETUP ABOVE THE BASIN

For all modifications except changing the pitch, the model can be lifted with the hexapod above the water surface using the overhead crane. Structures will be installed on the tripod to support the hexapod 0.8m above its nominal position, which will allow the entire rotor to remain above the water level for any modification or tests in air. This operation will take longer than the change of pitch in section 6.3, estimated between 1 and 2 hours.

7 REFERENCES

- [1] E. Boudière, C. Maisondieu, F. Arduin, M. Accensi, L. Pineau-Guillou, and J. Lepasqueur, "A suitable metocean hindcast database for the design of Marine energy converters," *Int. J. Mar. Energy*, vol. 3–4, pp. 40–52, 2013.



APPENDICES

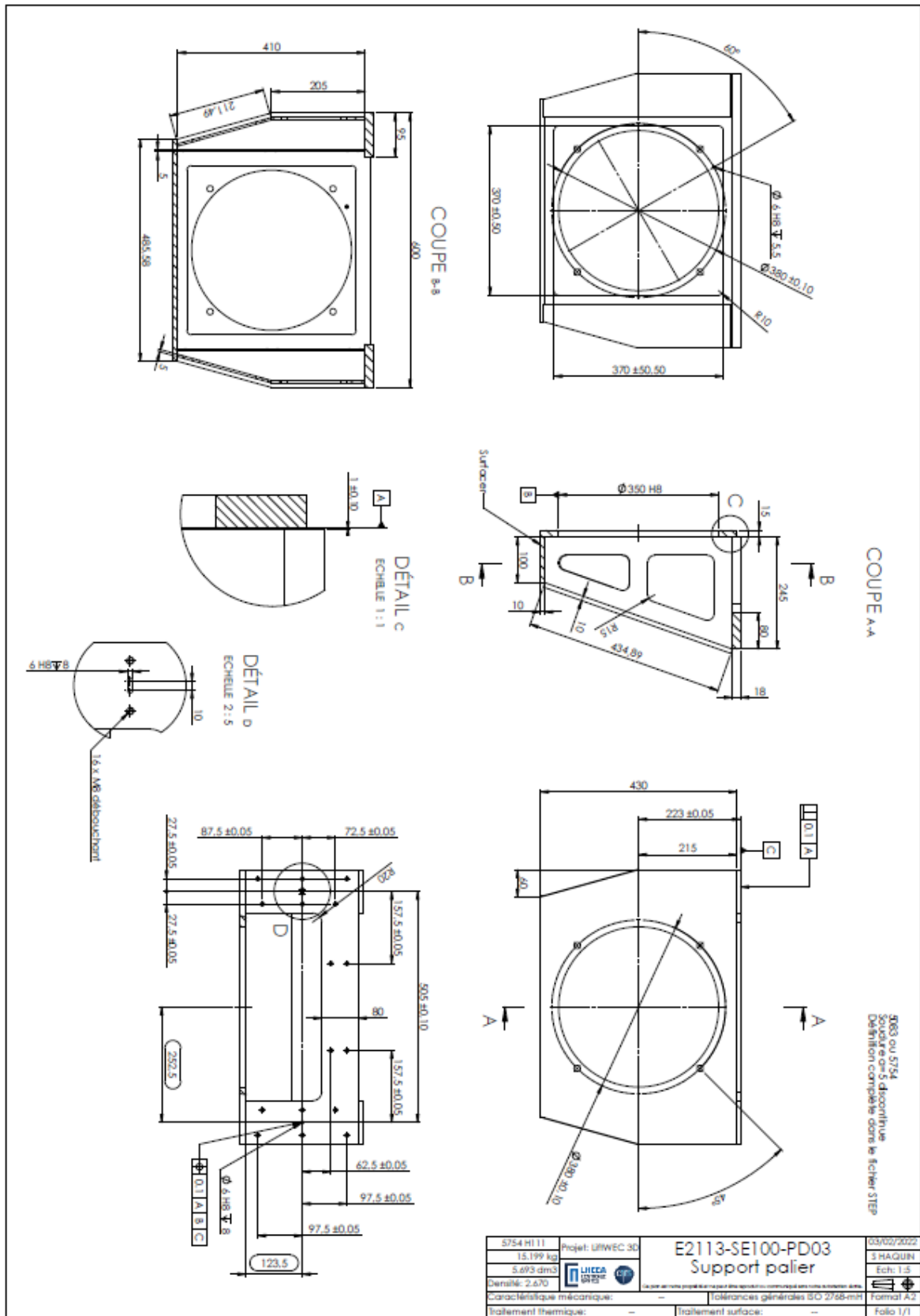

A. TECHNICAL DRAWINGS

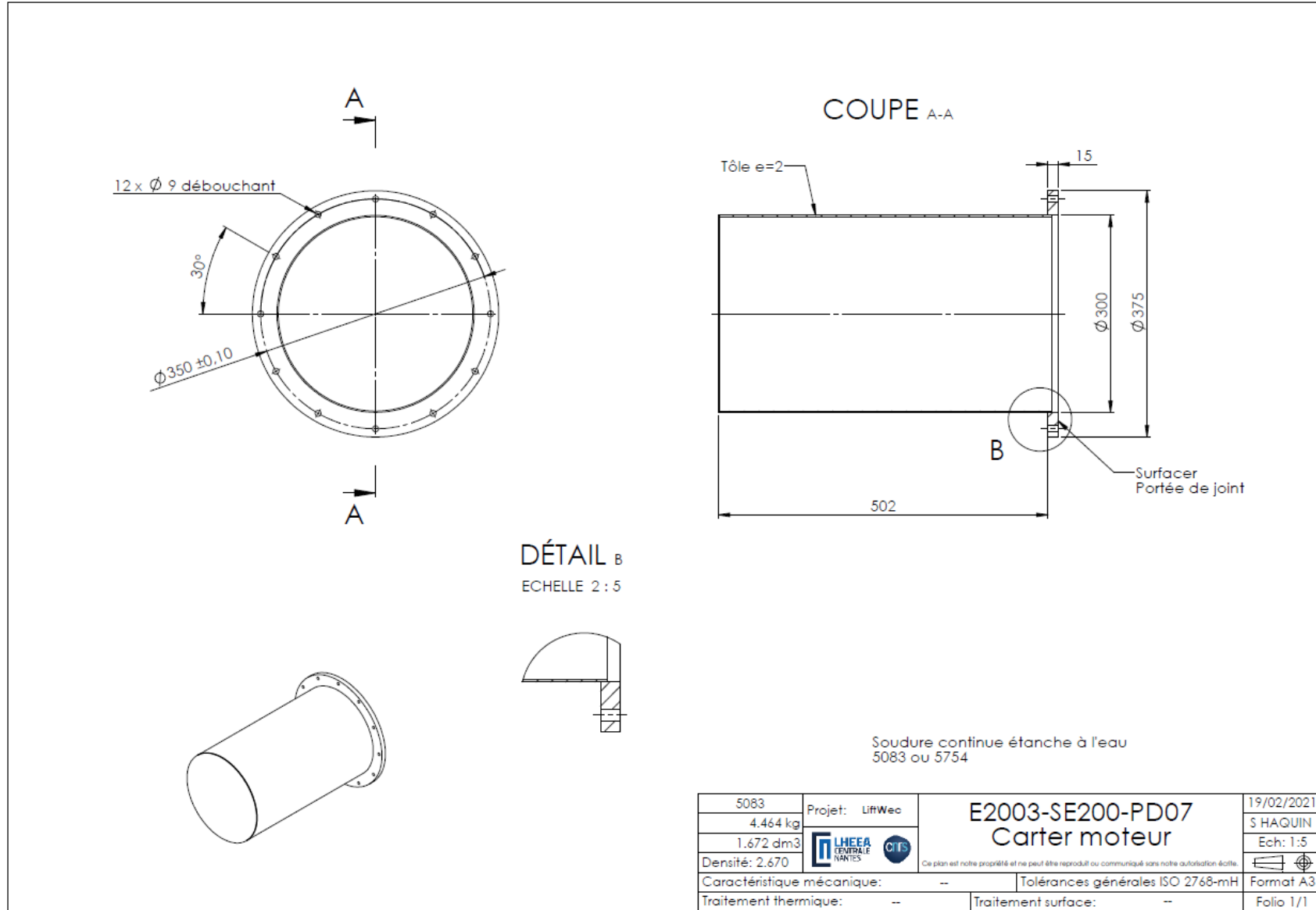

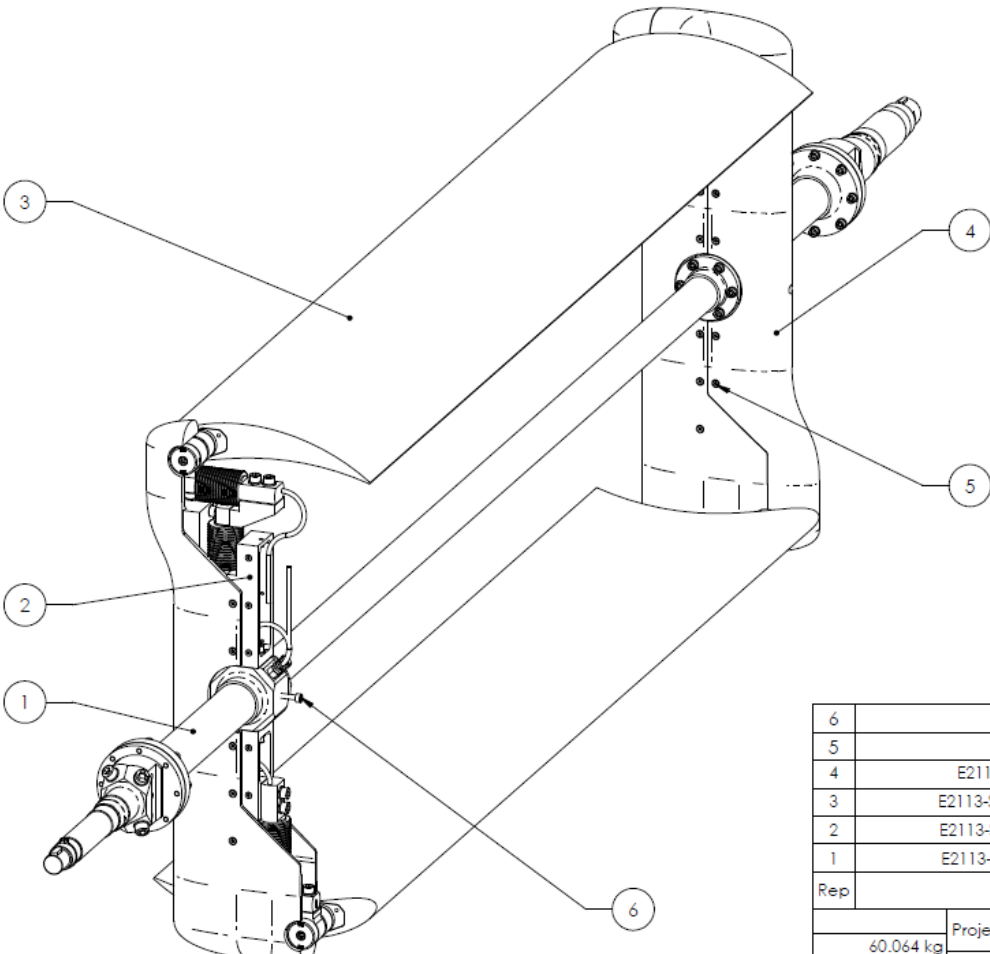



6	Vis CHC, M6-30	INOX A2	4
5	Vis FHC, M4-12	INOX A2	40
4	E2113-SE500-PD01 Habillage bras		4
3	E2113-SE300-PE01 Nomenclature pale		2
2	E2113-SE400-PE01 Nomenclature bras		4
1	E2113-SE200-PE01 Nomenclature axe		1
Rep	Désignation	Description	Qté

60.064 kg		Projet: LiftWEC 3D	E2113-SE500-PE01 Nomenclature rotor	21/02/2022
39.776 dm ³		 		S HAQUIN
Densité:		Ce plan est notre propriété et ne peut être reproduit ou communiqué sans notre autorisation écrite.		Ech: 1:5
Caractéristique mécanique: --		Tolérances générales ISO 2768-mH		Format A3
Traitement thermique: --		Traitement surface: --		Folio 1/1

DÉTAIL A
ECHELLE 1 : 3
Sans axe bras

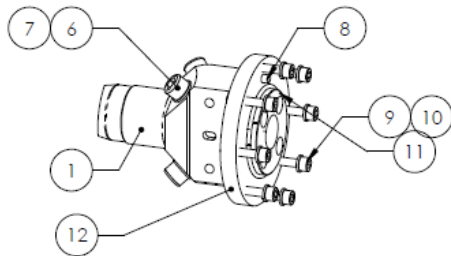

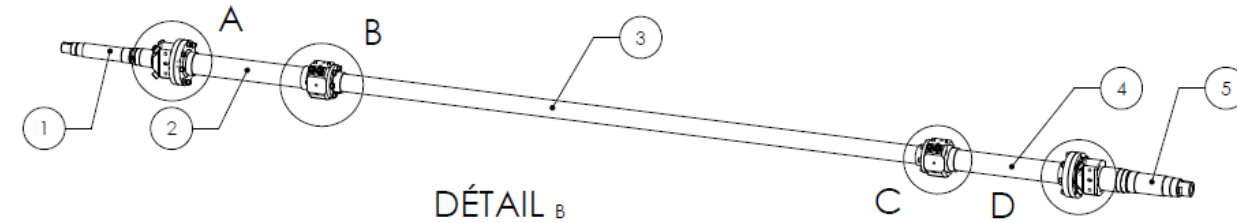

DÉTAIL B
ECHELLE 1 : 3
Sans entretoise axe

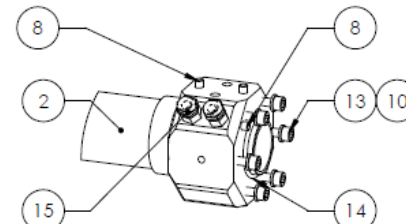

DÉTAIL D
ECHELLE 1 : 5
Sans la fusée

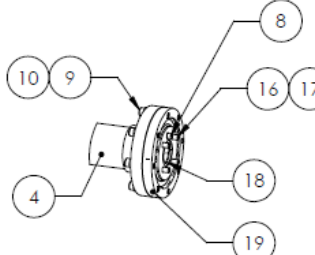

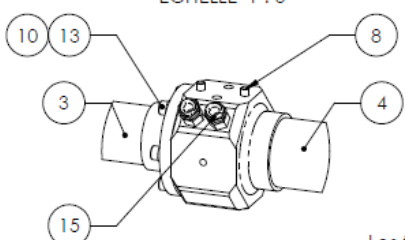

DÉTAIL C
ECHELLE 1 : 3



Les fusées sont déjà assemblées sur les paliers

19	E2113-SE200-PD02 Bride axe collecteur		1
18	Joint torique 25x2,5	NBR, dureté 70	2
17	Bague BS 205550	HUTCHINSON	8
16	Vis CHC,M6-16	INOX A2	8
15	Progress-MS-A1000.10.060	SES	8
14	Joint torique 40x3	NBR, dureté 70	2
13	Vis CHC,M6-20	INOX A2	12
12	E2113-SE200-PD01 Bride axe moteur		1
11	Joint torique 62x3	NBR, dureté 70	2
10	Rondelle M6	INOX A2	28
9	Vis CHC,M6-30	INOX A2	16
8	Pion de positionnement d6x10	316L étiré h9	14
7	Bague BS 205555	HUTCHINSON	8
6	Vis CHC,M10-10	INOX A2	8
5	E2003-SE200-PD11 Fusée collecteur		1
4	E2113-SE200-PD04 Axe bras collecteur		1
3	E2113-SE200-PD05 Entretoise axe rotor		1
2	E2113-SE200-PD03 Axe bras moteur		1
1	E2003-SE200-PD10 Fusée moteur		1
Rep	Désignation	Description	Qté

17.193 kg	Projet: LiftWEC 3D	E2113-SE200-PE01 Nomenclature axe	15/02/2022
2,769 dm3	 		S HAQUIN
Densité:		Ce plan est notre propriété et ne peut être reproduit ou communiqué sans notre autorisation écrite.	Ech: 1:10
Caractéristique mécanique: --		Tolérances générales ISO 2768-mH	 Format A3
Traitement thermique: --		Traitement surface: --	Folio 1/1

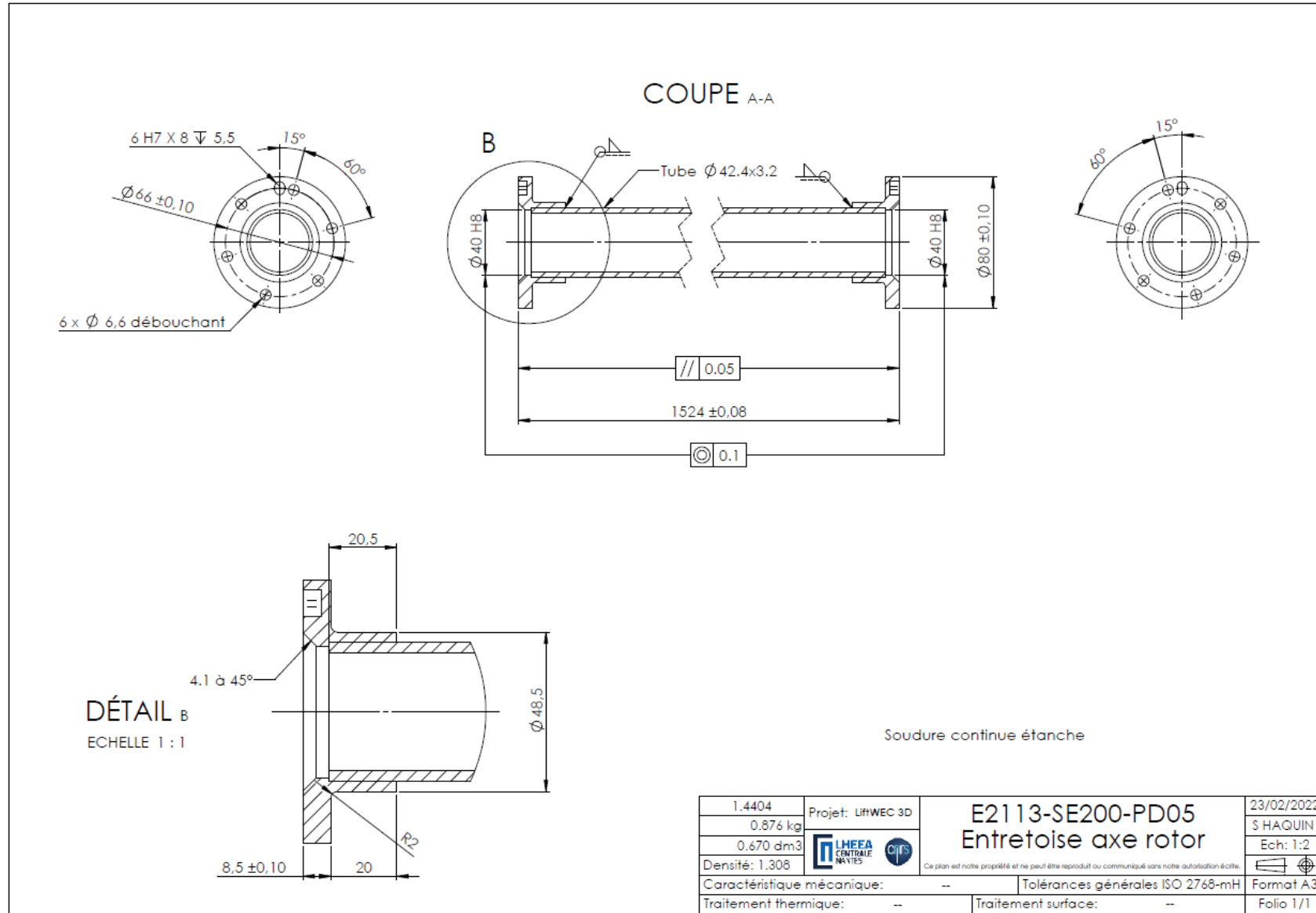

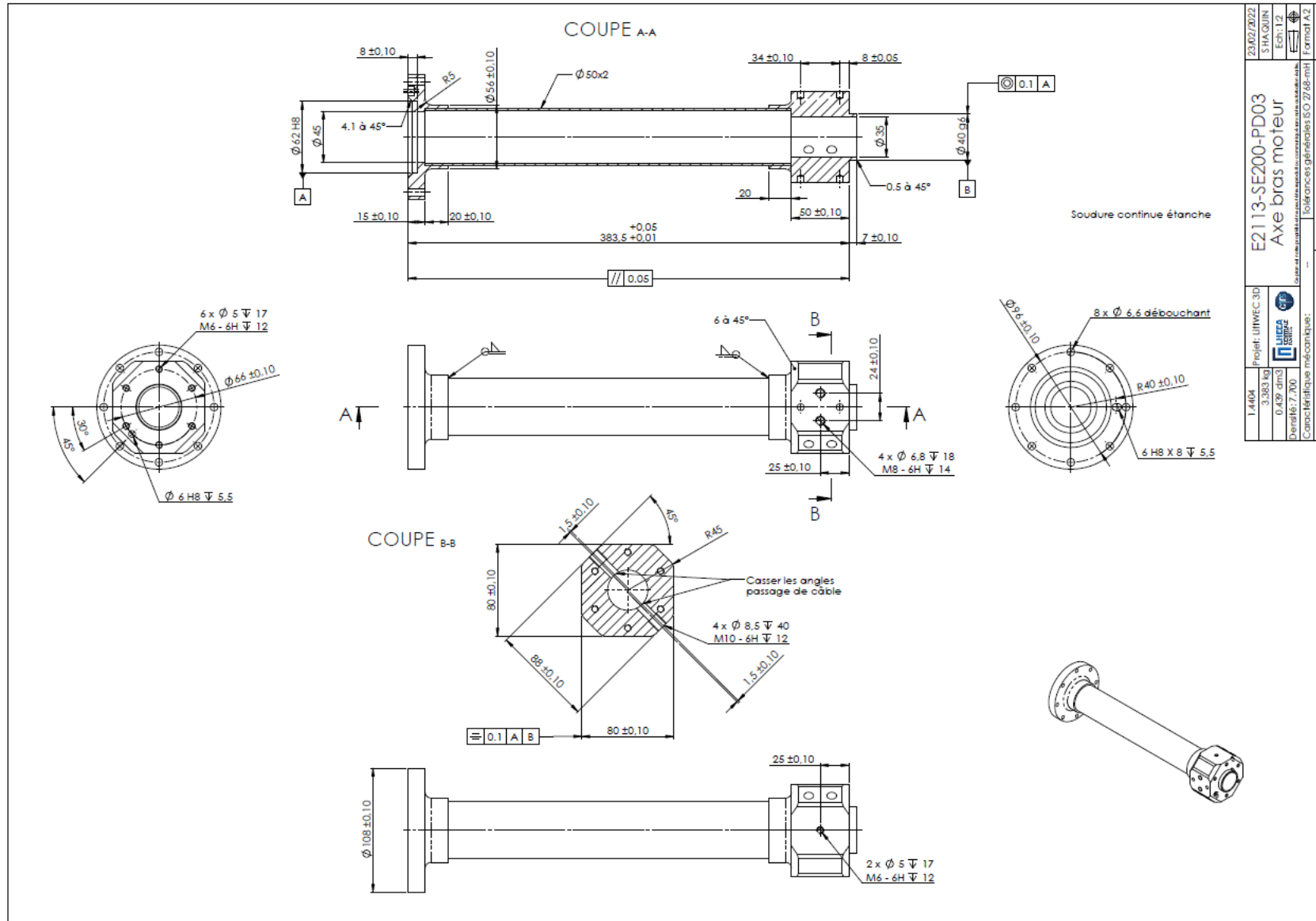

1.4404	Projet: LiftWEC 3D	02/02/2022
3.383 kg		3.114.0218
0.439 g/cm ³		Ech: 1/2
Caractéristique mécanique:		Format A2
1		Folio 1/1

E2113-SE200-PD03
 Axe bras moteur

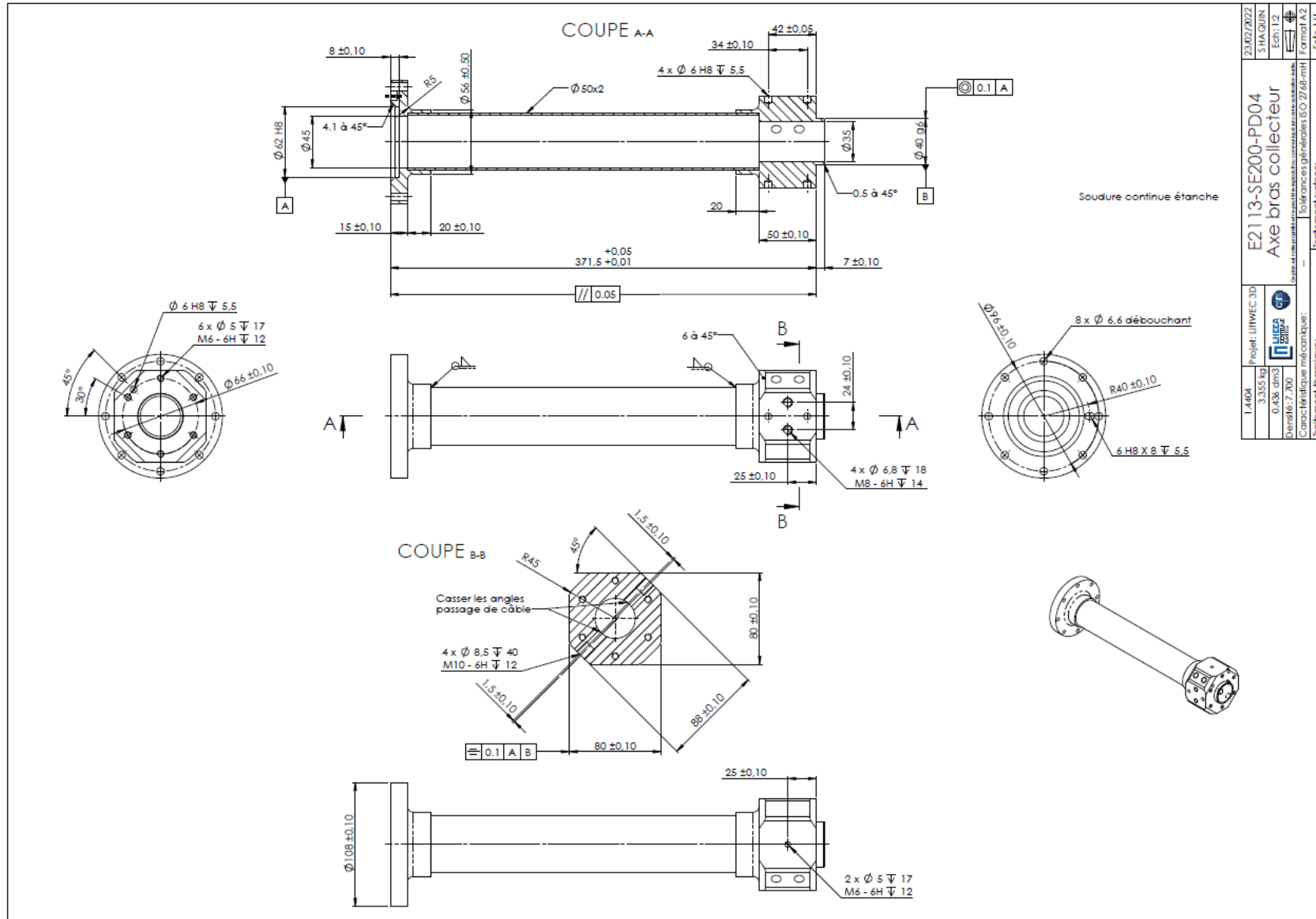

Tolérances géométriques ISO 2768-mS
 Traitement thermique: Soudure continue étanche

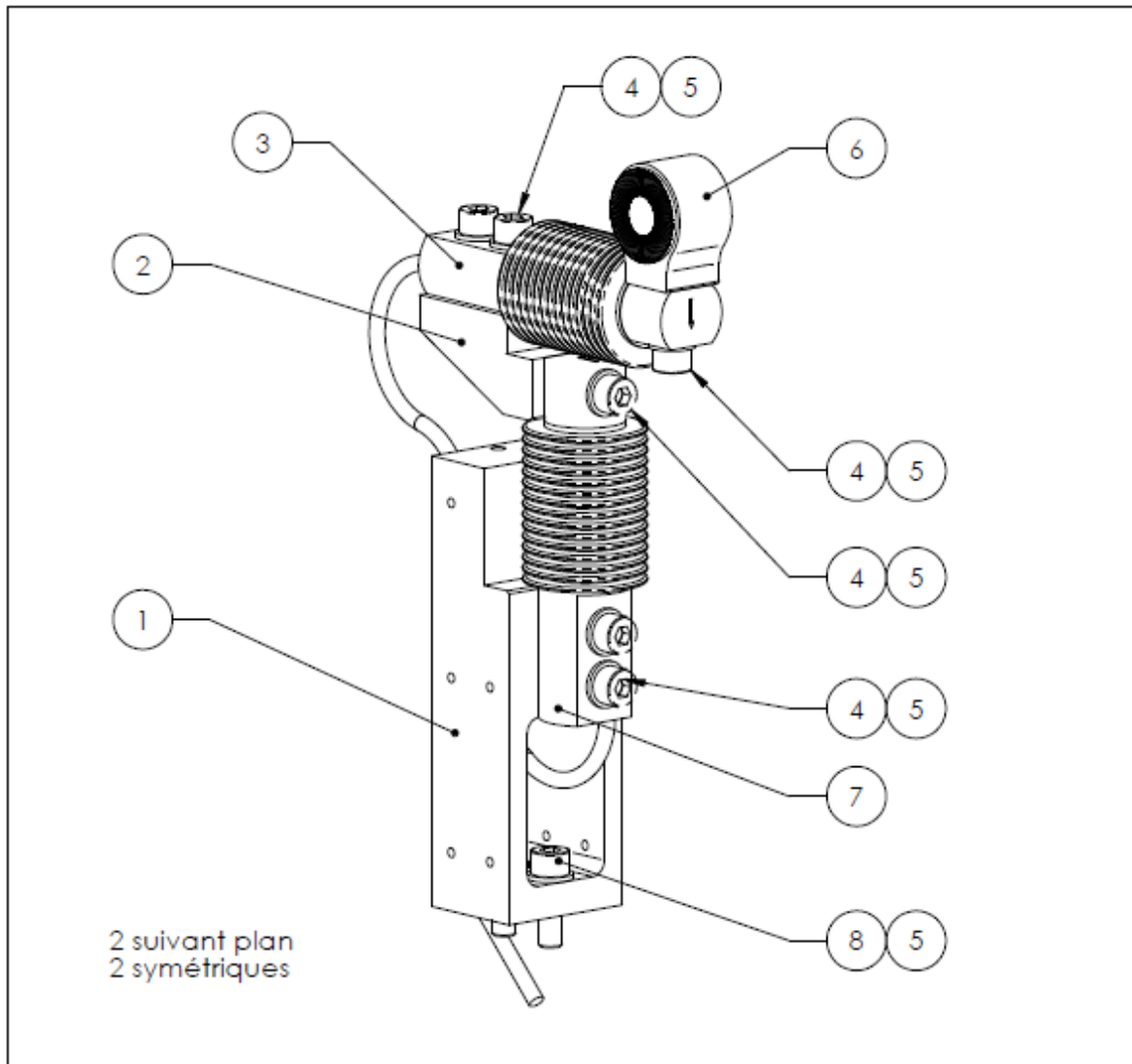

1.404	Projet: LIFTWEC 3D	23/07/2022
3.355 kd	3 HACHOIN	
0.436 dm3	Ech: 1:2	
Denrte: 7.700		
Caractéristique mécanique:	Tolérances générales ISO 2768-ml	
Traitement thermique:	Format A2	
		Folio 1/1



8	Vis CHC,M8-25	INOX A2	2
7	Z6FC3_30KG	HBM	1
6	E2113-SE400-PD03 Palier pitch		1
5	Rondelle M8	INOX A2	8
4	Vis CHC,M8-35	INOX A2	6
3	Z6FC3_50KG	HBM	1
2	E2113-SE400-PD02 Equerre capteur		1
1	E2113-SE400-PD01 Bras		1
Rep	Désignation	Description	Qté

Projet: LiftWEC 3D		E2113-SE400-PE01 Nomenclature bras	21/02/2022
2.553 kg	 		S HAQUIN
0.401 dm ³		Ce plan est notre propriété et ne peut être reproduit ou communiqué sans notre autorisation écrite.	
Densité:	Tolérances générales ISO 2768-mH		Ech: 1:2
Caractéristique mécanique: --		Format A4	
Traitement thermique: --		Folio 1/1	



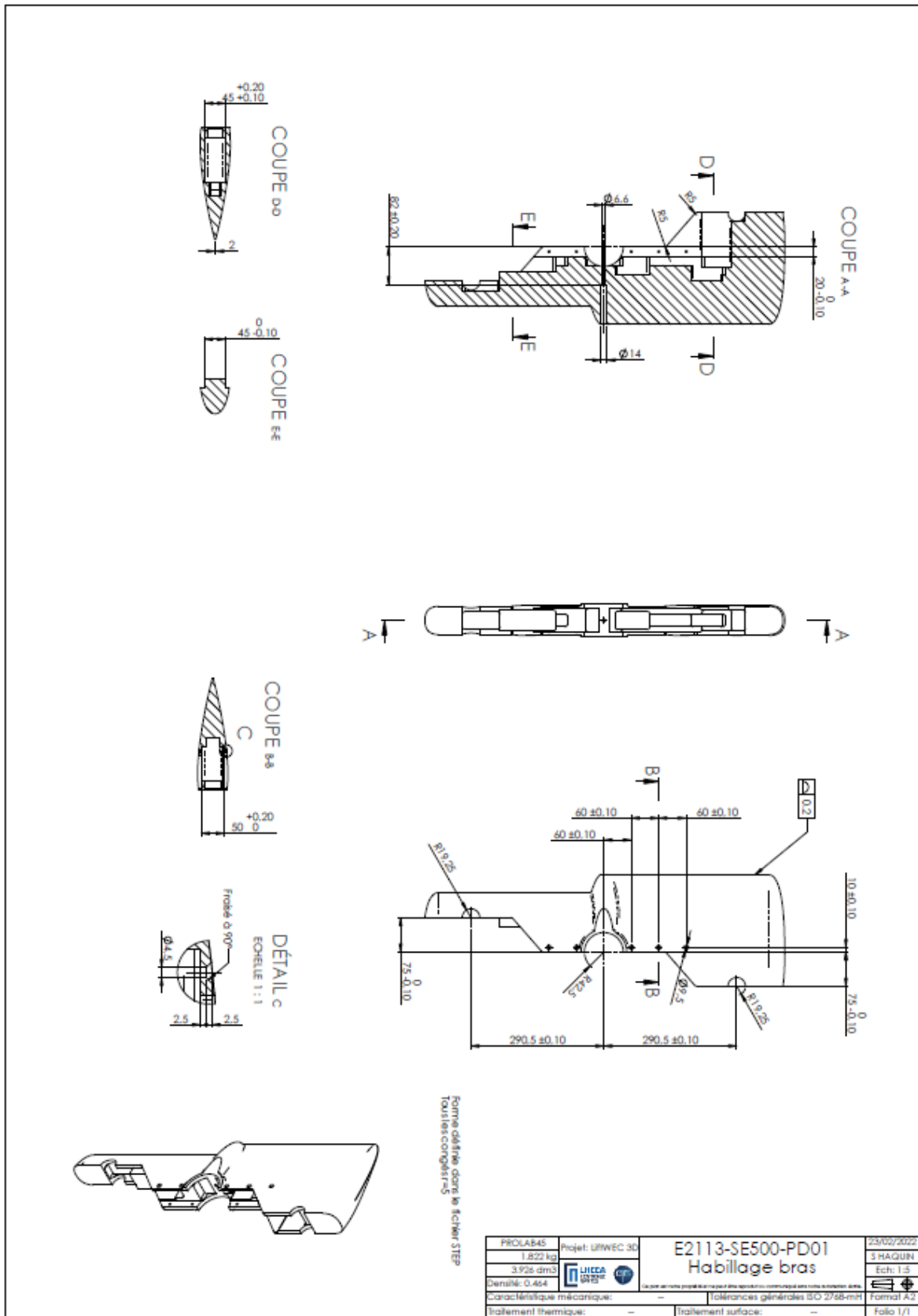

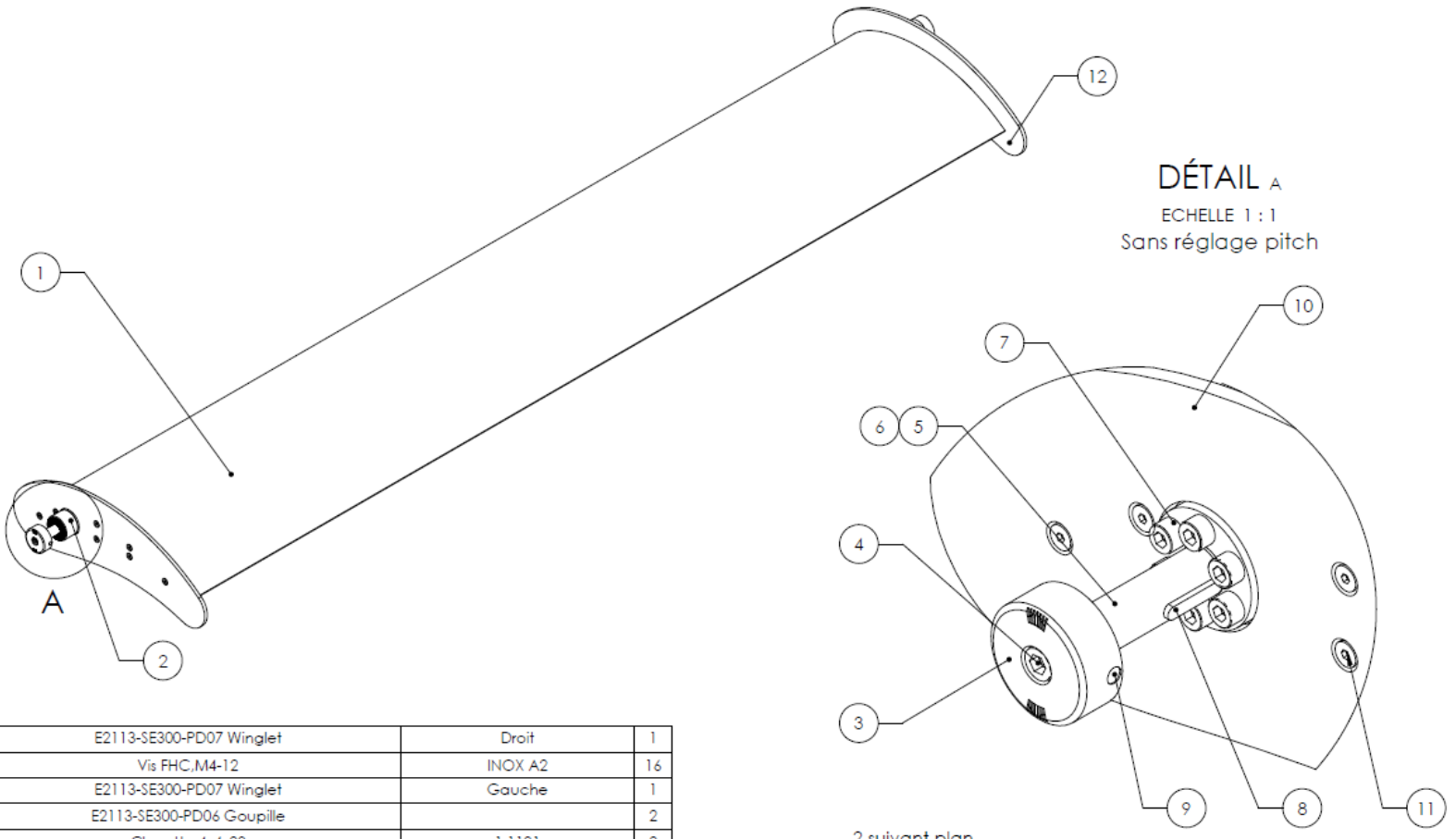



DÉTAIL A
ECHELLE 1 : 1
Sans réglage pitch

2 suivant plan

Coller la goupille dans l'entretoise

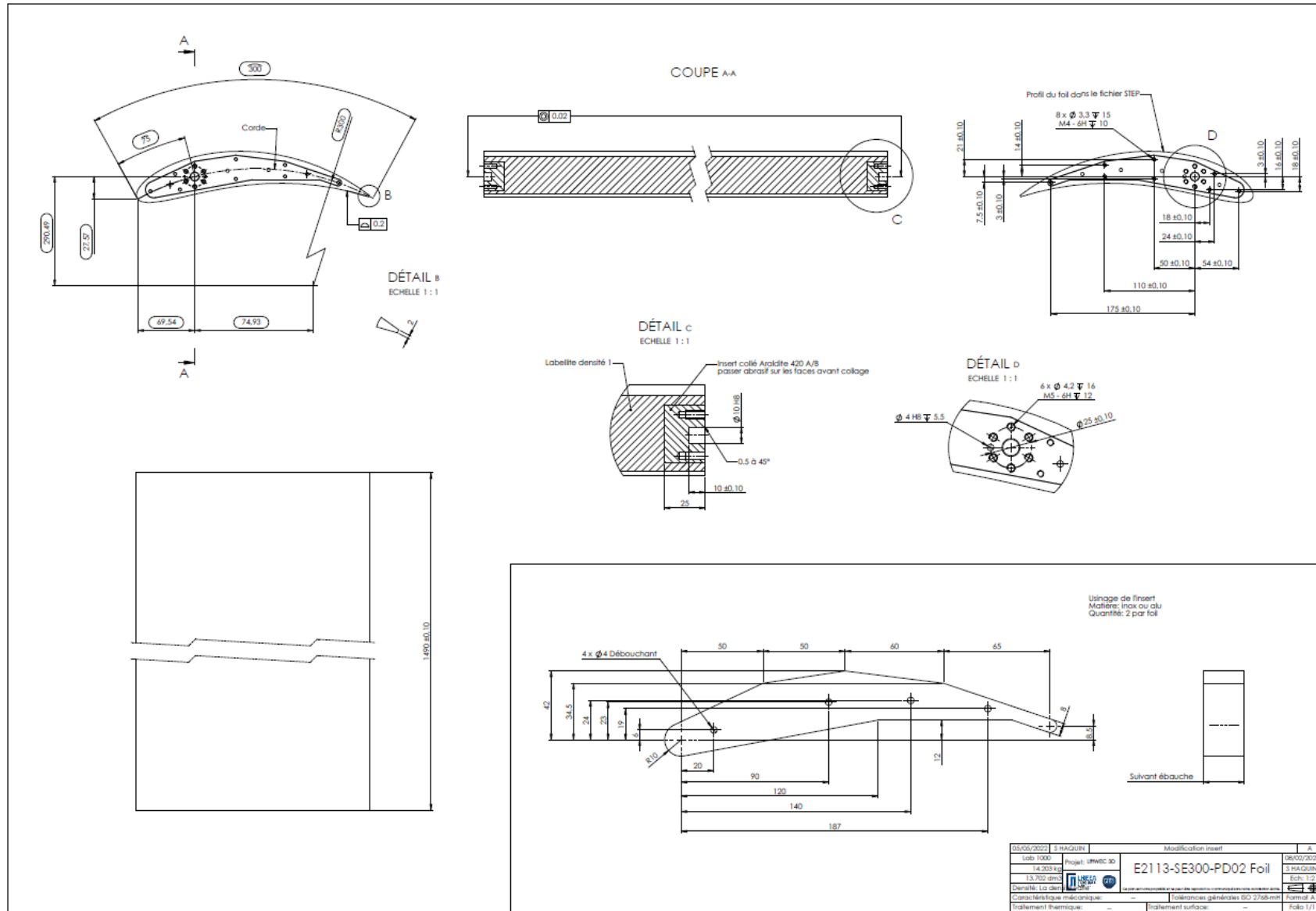

12	E2113-SE300-PD07 Winglet	Droit	1
11	Vis FHC,M4-12	INOX A2	16
10	E2113-SE300-PD07 Winglet	Gauche	1
9	E2113-SE300-PD06 Goupille		2
8	Clavette 4x4x20	1.1191	2
7	Vis CHC,M5-16	INOX A2	12
6	Pion de positionnement d4x10	316L éfilé h9	2
5	E2113-SE300-PD03 Axe pitch		2
4	Vis CHC,M6-12	INOX A2	2
3	E2113-SE300-PD05 Entretoise foil		2
2	E2113-SE300-PD04 Réglage pitch		2
1	E2113-SE300-PD02 Foil		1
Rep	Désignation	Description	Qté

15.640 kg	Projet: LIFWEC 3D	E2113-SE300-PE01 Nomenclature pale	21/02/2022
14.084 dm ³	 		S HAQUIN
Densité:		<small>Ce plan est notre propriété et ne peut être reproduit ou communiqué sans notre autorisation écrite.</small>	Ech: 1:5
Caractéristique mécanique:	--	Tolérances générales ISO 2768-mH	Format A3
Traitement thermique:	--	Traitement surface: --	Folio 1/1

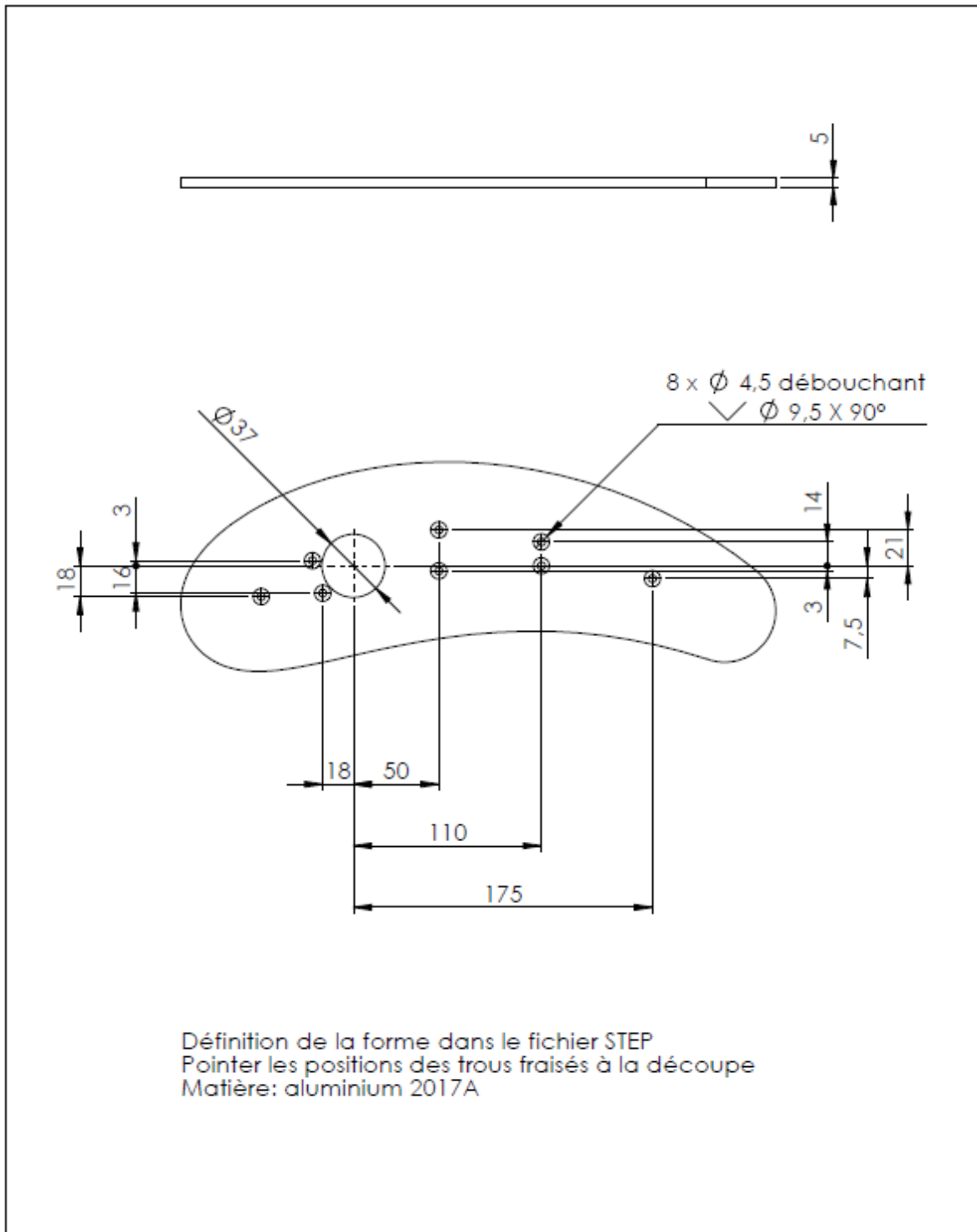

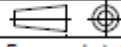

Définition de la forme dans le fichier STEP
Pointer les positions des trous fraisés à la découpe
Matière: aluminium 2017A

2017A	Projet: LiftWEC 3D	E2113-SE300-PD07 Winglet	09/06/2022
0.408 kg	 		S HAQUIN
0.146 dm ³			Ech: 1:3
Densité: 2.790		<small>Ce plan est notre propriété et ne peut être reproduit ou communiqué sans notre autorisation écrite.</small>	
Caractéristique mécanique: --		Tolérances générales ISO 2768-MH	Format A4
Traitement thermique: --		Traitement surface: --	Folio 1/1

